

# INKOMA /ALBERT

Great ideas need drive.

## KL SPIRAL BEVEL GEAR UNITS





**INKOMA-spiral bevel gear units type KL** incorporate Klingenberg Spiral Bevel Gears. This results in high efficiency and a very high torque transmission capability.

INKOMA-spiral bevel gear units are very quiet. Their compact and symmetrical dimensions provide a space-saving drive layout.

**Notable** about this design is a newly patented feature of the INKOMA-spiral bevel gear unit type KL. This allows a simple means of backlash adjustment without the need for disassembly.

For normal applications the INKOMA-spiral bevel gear unit type KL is lubricated for life.

For applications involving particularly high speeds and duty a breather is provided and periodical lubricant replacement is advisable.

# TECHNICAL INFORMATION

MODEL

RATIO

KL-0	1:1 / 1,5:1 / 2:1 / 3:1
KL-1	1:1 / 1,5:1 / 2:1 / 3:1 / 4:1 / 5:1 / 6:1
KL-2	1:1 / 1,5:1 / 2:1 / 3:1 / 4:1 / 5:1 / 6:1
KL-23	1:1 / 1,5:1 / 2:1 / 3:1 / 4:1 / 5:1 / 6:1
KL-25	1:1 / 1,5:1 / 2:1 / 3:1 / 4:1 / 5:1 / 6:1

INKOMA-SPIRAL BEVEL GEAR UNIT TYPE KL  
IS AVAILABLE IN THE FOLLOWING STANDARD VERSIONS

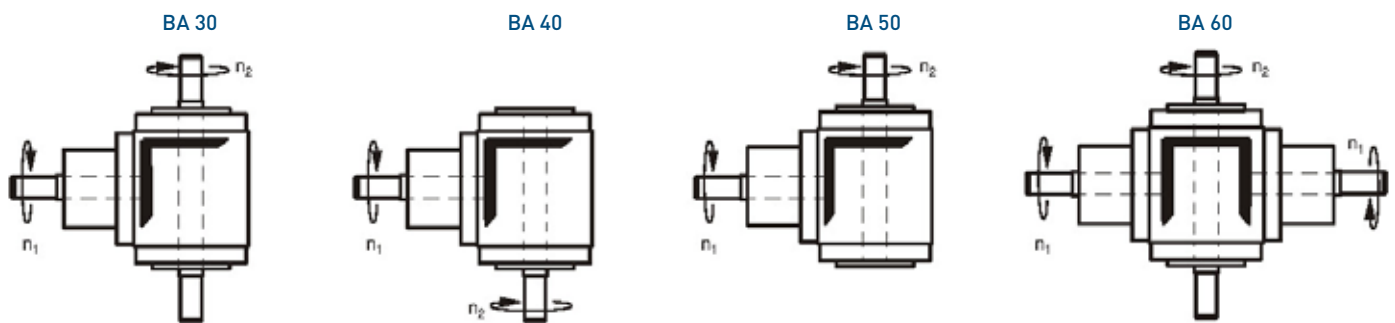

Special sizes and executions are possible, please enquire.

THE DESIGN OF THE INKOMA-SPIRAL BEVEL GEAR UNIT TYPE KL  
MAKES IT EASY TO USE IN COMBINATION WITH OTHER PRODUCTS

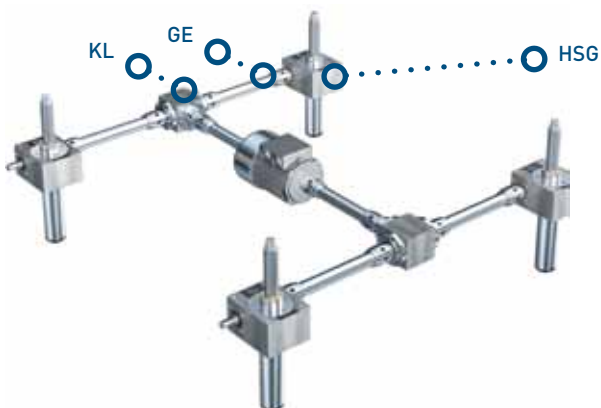

KL spiral bevel gear unit  
HSG precision screw jack  
GE cardan shaft

Request our complete catalogue or visit us on the Internet.  
You can obtain a free download of our brochure or the product drawing of  
the selected item using the CADENAS facility.

# INKOMA /ALBERT

Great ideas need drive.



© Maschinenfabrik INKOMA 2014  
Photography, layout, concept: www.fbwk.at

[www.inkoma.de](http://www.inkoma.de)

INKOMA Maschinenbau GmbH  
Lange Göhren 14  
D- 39171 Osterweddingen  
T: +49 (0) 39205 453-0  
F: +49 (0) 39205 453-433  
[info@inkoma.de](mailto:info@inkoma.de)